



# GANZ ENGINEERING AND ENERGY PRODUCTION MACHINERY LLC.

# HYDRO TURBINES

# TABLE OF CONTENTS

- GANZ HYDRO-POWER ..... 1
- RANGE OF STANDADIZED TURBINES ..... 3
- FRANCIS TURBINES ..... 4
- KAPLAN TURBINES ..... 8
- PELTON TURBINES ..... 13
- A FEW INTERESTING HISTORICAL FACTS... ..... 18

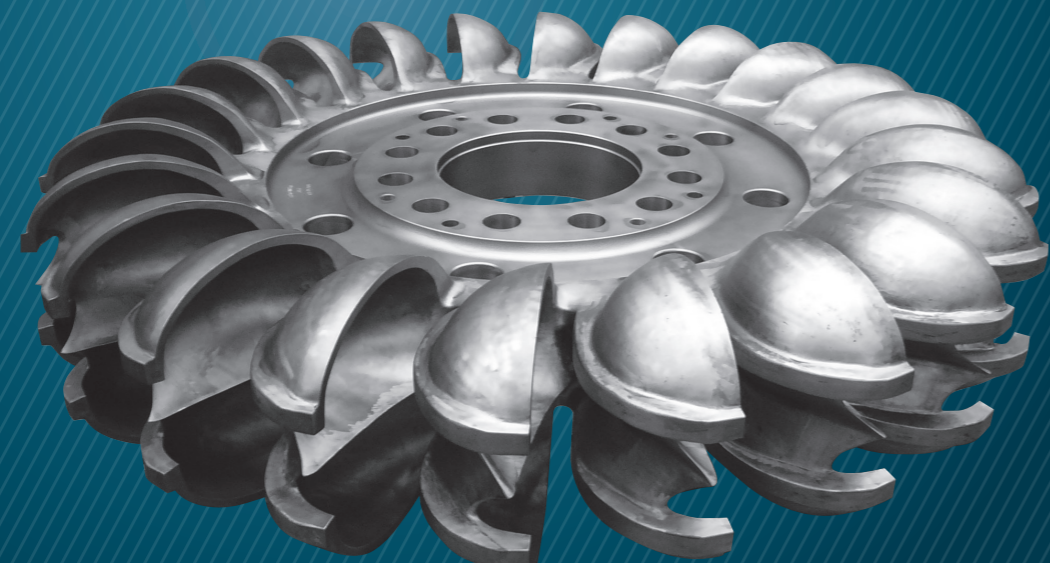

# GANZ HYDRO-POWER

...OFFERING THE LEAST ENVIRONMENT DAMAGING SOURCE OF ENERGY.

Ganz Energetics Ltd. specialises in advanced mechanical engineering production, having a high technological content. One of the main fields of activities is the research, development, design and manufacturing of mechanical equipment involved in hydro-power generation of medium size.

Apart from the full range of turbines, a comprehensive range of ancillaries is offered that ensures the efficient and safe operation of a modern power station. modern power station.

Backed by the company's own test station, the new ideas were extensively tested, leading to an ever-increasing turbine efficiency. The conducted model tests also serve as a basis for efficiency and cavitations guaranties.

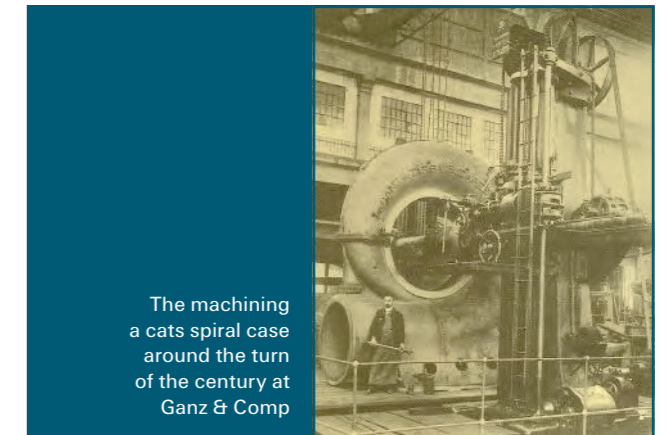

The machining a cats spiral case around the turn of the century at Ganz & Comp

A considerable amount of effort was made to develop a standardised range of turbines, thereby to utilise the cost effectiveness of such designs, but each of our deliveries is carefully tailor made in details to meet the individual requirements of the project.

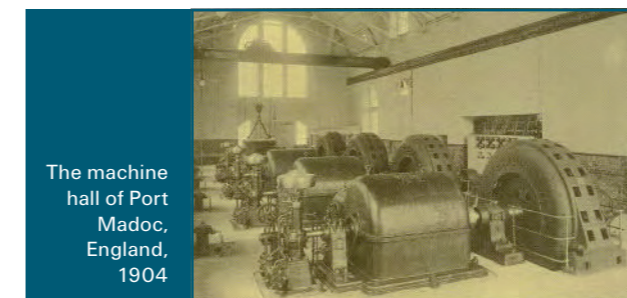

The machine hall of Port Madoc, England, 1904

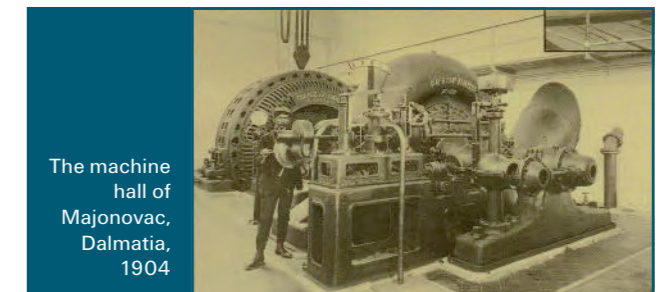

The machine hall of Majonovac, Dalmatia, 1904

GANZ HYDRO-POWER



Bird's view of our premises

Founded in 1844 as a foundry, Ganz initially produced various castings for the railways and the food processing industry, but soon adopted other currently available, then advanced manufacturing techniques and the production of mechanical machinery begun.

The first turbine was delivered as early as 1866, a Jonval type machine (H=4.46 m, Q=66 l/sec), which remained in continuous operation for the coming 31 years. After its refurbishment in 1897, it remained in service until 1950.

Even though the natural waterpower resources of Hungary are scarce and, consequently, the local demand for turbines was always low, our reliable products secured a constant flow of orders from the international market, for over a century. Nearly 3000 machines were delivered to four continents.

The experience gained by the many generations of craftsmen and the introduction of modern production technologies with the commitment to continually upgrade products, resulted in machines that proved to perform reliably and safely throughout their design life at reasonable costs.

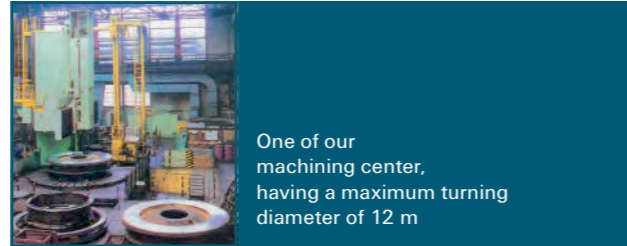

One of our machining center, having a maximum turning diameter of 12 m

The stable staff of highly qualified researchers, engineers, craftsmen and production supervisors ensures the high quality of our products and the continuity of cooperation with its clients.

The production range of the Pelton, Francis, Kaplan and all type of axial-flow (tubular, bulb-, pit- and S-type) turbines are standardized up to 5 MW unit power, but the supply of tailor made machines up to 50 MW unit power are also undertaken.

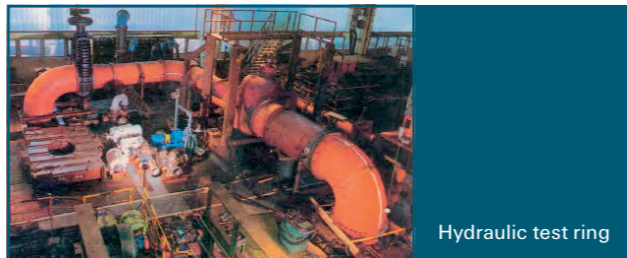

Hydraulic test ring

# RANGE OF STANDARDIZED TURBINES

The H-Q diagram (fig.1) gives the application field of each turbine type. For areas overlapped by two types of machines, a continued study of relative efficiency and the effect of the acceptable suction head on the civil works costs must be considered.

### RELATIVE EFFICIENCY

Each type of turbine has a characteristic way to run at partial loads, as represented by fig.2., accordingly should there be a large fluctuation in the water supply, the machine with a flatter curve must be preferred.

### SUCTION HEAD

The suction head determines the setting of the runner as compared to the tail race level for the reaction type turbine, so the selection of a machine with a better suction capacity, would save on the cost of the civil works.

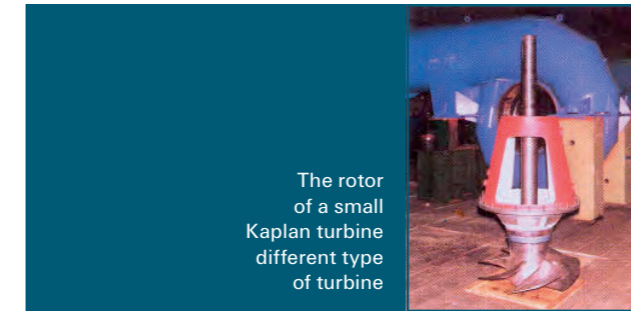

The rotor of a small Kaplan turbine different type of turbine

At the same time the suction head decreases by elevation, accordingly, probably a Pelton would be more feasible for a project at high altitudes, provided both the Pelton and the Francis type are applicable.

Fig. 1. Range of standardised Hydro Turbines

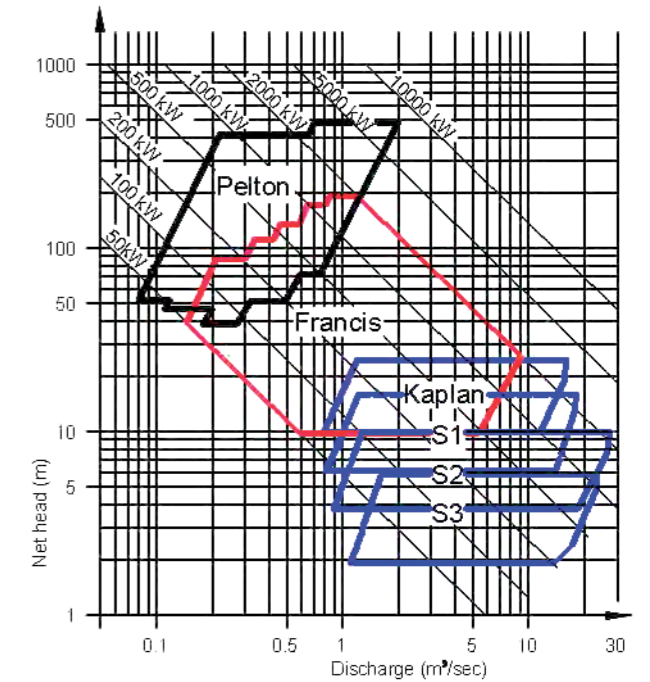
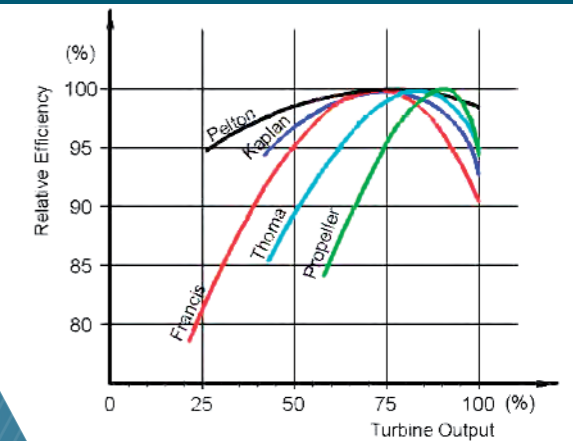

Fig. 2. Relative efficiency comparison of different type of turbines



# FRANCIS TURBINES OUTPUT RANGE 0,1-5 MW

## ARRANGEMENT

Ganz has two standard design Francis turbine groups, both having horizontal shaft arrangements.

In the first group, the runner is mounted directly on the free end of the generator shaft, thus the weight and thrust of the runner are absorbed by the generator bearing. In case, the unit must be fitted with a flywheel, it may be mounted on the non-drive end of the generator shaft. This solution results in a very compact, space saving arrangement. In the second group, the turbine is complete with a guide and thrust bearing and the turbine shaft is rigidly coupled by a flanged coupling to the generator shaft, thus the role of the other guide bearing is fulfilled by the generator bearings. The flywheel, if applicable, may be mounted between the faces of the rigid coupling. This arrangement offers the facility of employing a standard design generator, which may be advantageous from an economic point of view. Special version of the turbines may be supplied, on request, with full bearings and with flexible coupling, or for high outputs, with rigid couplings.

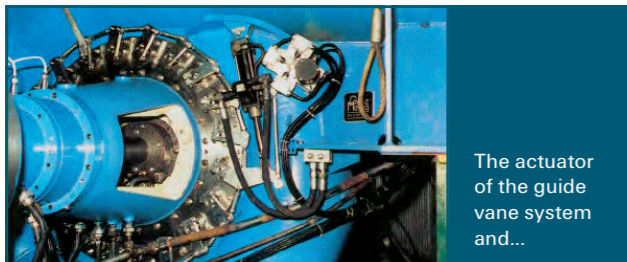

The actuator of the guide vane system and...

## CONTROL

The turbine is regulated by an adjustable guide vane system, operated by a hydraulic cylinder, which is actuated by the pressurized oil from the hydraulic power unit.

## ANCILLARY EQUIPMENT

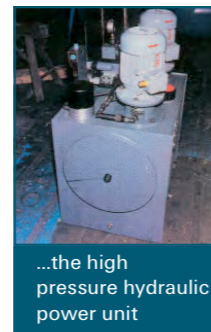

...the high pressure hydraulic power unit

### Frequency governor

A plant operating stand-alone, continually or periodically, must be equipped with a frequency governor. Our digital governor automatically controls the frequency and takes care of all other functions, facilitating unattended operation.

### Turbine controller

For a plant operating continually parallel with a large grid and having an asynchronous generator installed, an output and/or water level regulator is adequate.

### Hydraulic power unit

The hydraulic power unit is responsible for continually supplying the pressurized oil to the governor/controller unit. It consists of electric motor driven pumps, a pressure accumulator, various valves and safety devices.



The runner of Tetovo power station, Macedonia

## FRANCIS TURBINES

### Main inlet valve

For a low head plant (up to 180 m), a butterfly valve is normally installed in front of the turbines, whose closing is assisted by a closing weight and opening is controlled by a hydraulic cylinder. In case of a high head plant the same function is fulfilled by a spherical valve, whose actuation is accomplished by a double acting hydraulic cylinder.

## EFFICIENCY

The efficiency guarantees are based on the model tests of the five types of runners and on the prototype measurements of the matching turbines.

## TECHNICAL SPECIFICATION

The turbines are characterized by study and uncomplicated parts, resulting in a very reliable operation with minimal maintenance.

### Spiral casing with stay ring

The spiral casing is a single piece, a welded construction from carbon steel plates, complete with mounting feet, lifting lugs and port for pressure and flow gauges. The design ensures a uniform and circularly symmetric flow to the runner.

### Guide vane assembly

The guide vane assembly is complete with stainless steel cast vanes and unalloyed steel levers with incorporated slip clutches. The vane trunnions are supported by dry sliding bearings and the turbine covers are made of carbon steel with stainless steel protection.

### Runner

The runner is an integrally cast stainless steel member, statically and dynamically balanced.

### Shaft sealing

Two alternatives exist, a conventional PTFE type and a Mechanical type. In both cases the exposed section of the shaft is protected by a wearing sleeve.

Fig. 1. Horizontal shaft Francis turbine dimension

Type	A	B	C	E	F	G	J	ØK	ØL	M
Fs 1	2.4-2.8	2.02	1.41	1.11	1.15	1.13	1.28	0.86	1.56	0.47
Fs 2	2.4-2.8	2.12	1.48	1.15	1.125	1.18	1.34	0.95	1.74	0.52
Fs 3	2.4-2.8	2.23	1.59	1.22	1.40	1.24	1.43	1.08	1.92	0.58
Fs 4	2.4-2.8	2.46	1.72	1.26	1.70	1.30	1.53	1.30	2.15	0.65
Fs 5	2.4-2.8	2.57	1.76	1.28	1.83	1.32	1.56	1.38	2.22	0.67

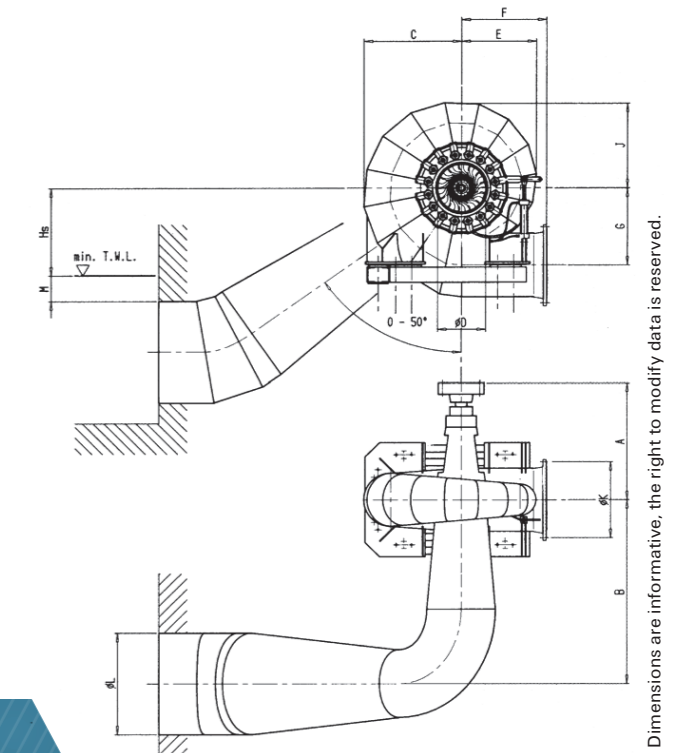

FRANCIS TURBINES

Fig. 2. Machine selection chart for Francis turbines

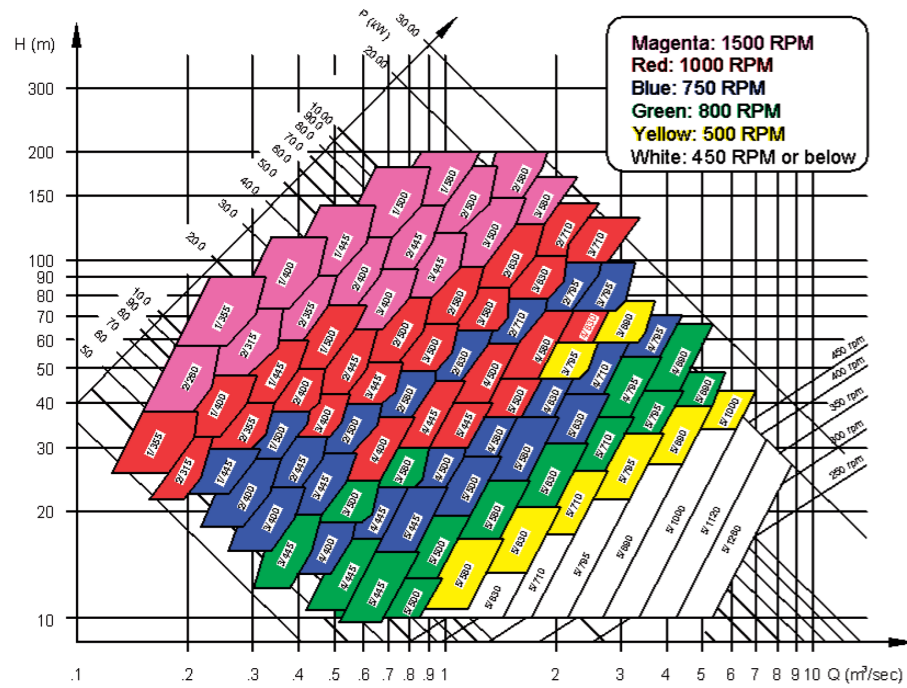
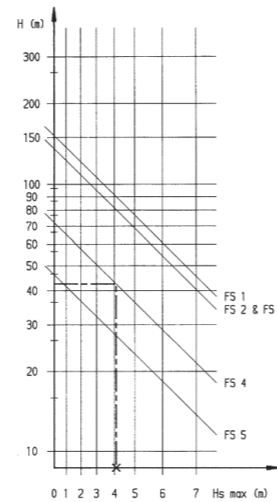

Fig. 3. Admissible turbine settings

Example for using the charts:

Head: H = 42 m  
 Discharge: Q = 1.4 m³/sec  
 Turbine output: P = 500 kW  
 Turbine settings: Hs = 4 m  
 Runner type: 4  
 Nominal runner dia.: D = 500 mm  
 Speed: n = 1000 rpm  
 Designation of turbine: Fs 4/500-1000



Draft tube

The draft tube consists of the discharge bend and the suction cone, both being a welded construction from mild carbon steel plates.

Bearing

The thrust and guide bearing, (if applicable) is an oil lubricated and self aligning type, mounted in a common

housing. It is complete with a cooling facility and have port for a contact thermometer.

MACHINE SELECTION

The following section will furnish information to determine the type and dimensions of the turbine applicable to a given situation.

FRANCIS TURBINES

Guidelines for reading the diagrams

1. Determine the net head H (m), the water flow for each unit Q (m³/sec) and the elevation above mean sea level of the site.
2. Establish the operation field by matching the values of H & Q against each other on fig. 2. The first number defines the runner type, the second the runner diameter and the color code represents the speed.
3. Determine the applicable operation speed.
4. Define the acceptable suction head, using fig. 3. From the obtained suction head subtract 1 m for every 1000 m of elevation of the site location.
5. Determine the main dimensions of the turbine in ratio of runner diameter using fig. 1.



A spiral case in the sheet metal shop Dadin Kowa project, Niger



A low head Francis spiral case ready for machining, Karnah power station, Kashmir, India



Welded runner for Barnes Bridge project, England



# KAPLAN TURBINES

OUTPUT RANGE 0,1–5 MW

## ARRANGEMENT

Several arrangements have been developed to obtain the most cost effective solution for any given project. Apart from technical considerations, the possible cost of erection and costs involved in running and maintaining the unit were also considered.

### *Tubular Kaplan with bevel gear*

For the smaller output (fig. 1.), the Tubular type arrangement is offered with a bevel gear located within the bulb and having a high speed drive shaft perpendicular to water flow. The result is a very compact machine with the possibility to employ a standard high speed generator.



Fig. 1.  
The cooling system of several thermal power stations were installed with our recuperative Kaplan turbines. The machines on the picture were delivered to Trakya project in Turkey

### *S-type Kaplan*

For medium outputs, where the bulb is not yet large enough to accommodate a generator but a bevel gear cannot transfer the output any more, the S-type arrangement is proposed (fig. 2.). The water passage is still considerably straight, thus, excessive losses on that account are not sustained.

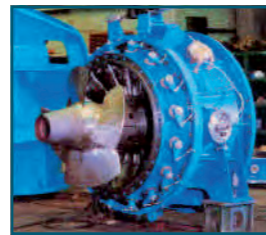

Fig. 2.  
A tubular Kaplan is prepared for its test run at our premises, Razdan project Armenia

### *Standard Kaplan*

For large outputs, a general study was also conducted to develop a machine complete with a vertical shaft arrangement, which can be offered with either a full spiral or semi spiral made out of concrete (fig. 3.).

This machine is complete with a guide bearing and it uses a common thrust bearing with the generator, for axial support



Fig. 3.  
The turbine upper cover with the guide vane assembly and the rotor is being lowered, Datong project China

## KAPLAN TURBINES

## CONTROL

These types of machines are controlled by an adjustable guide vane system, similar to the Francis machines and, in addition, the runner blades may also be adjusted securing high efficiency over a wide operation range.

Three sorts of arrangements are available with either or both types of controls, but for economic considerations, a smaller machine may only have one of the controlling facilities. Especially this is the case when the water flow is uniform.

## ANCILLARY EQUIPMENT

### *Frequency governor*

A plant operating stand-alone, continually or periodically, must be equipped with a frequency governor. Our digital governor automatically controls the frequency and takes care of all other functions, facilitating unattended operation.

### *Turbine controller*

For a plant operating continually parallel with a large grid and having an asynchronous generator installed, an output and/or water level regulator is adequate.

### *Hydraulic power unit*

The hydraulic power unit is responsible for continually supplying the pressurized oil to the governor/controller unit. It consist of electric motor driven pump(s), a pressure accumulator, various valves and safety devices.

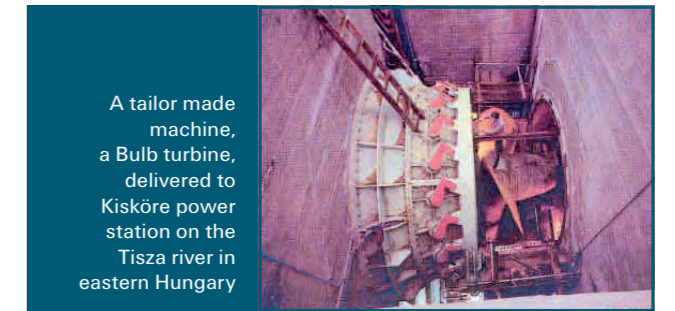

A tailor made machine, a Bulb turbine, delivered to Kisköre power station on the Tisza river in eastern Hungary

### *Main inlet valve*

The large flow rate and the absence of a long penstock facilitate the use of stop logs after the trash rack system and at the tail race exit. It is operated independently from the turbine control, which on the other hand, initiates its closing and opening procedure.

## EFFICIENCY

Three runners have been developed and a well documented prototype measurement series were carried out of each arrangement to secure competitive efficiency. The former figure also illustrates the relative efficiency to be expected from a machine having different control system.

## TECHNICAL SPECIFICATION

The goal in designing, was same as for the Francis turbine, to have an uncomplicated, yet, up-to-date and reliable machine.

KAPLAN TURBINES

*Bulb and stay ring*

The bulb with its supporting vanes and the outer ring is a welded construction from carbon steel plates, complete with anchorages.

*Guide vane assembly*

The inner and outer mild steel ring of the guide vane assembly is attached to the bulb and to the stay ring by releasable fastening. It is complete with the stainless steel cast vanes and the unalloyed steel levers with incorporated safety slip clutches. The vane trunnions are supported by dry sliding bearings. In case of fixed guide vanes, mild steel vanes are welded to the two rings.

*Runner chamber*

The runner chamber is a fabricated stainless steel ring, having accurately machined inner surface and ribs from the outside to increase rigidity.

*Runner*

The runner has cast stainless steel blades and a cast steel hub, which also accommodates the blade controlling mechanism for machines having adjustable runner blades. The fixed blade type machines also have the possibility to have the blade angle setting adjusted, as the blades are mounted by releasable fastening.

*Shaft sealing*

A conventional PTFE type seal and alternatively a Mechanical seal is employed, both complete with wearing ring attached to the shaft at the exposed surface.

*Draft tube*

All arrangements have a draft tube lining as long as erosion problem may occur. It is a welded construction from mild carbon steel plates.

*Bearing*

Except for the Standard Kaplan arrangement all others have proper bearing, capable of absorbing the axial and radial loads, thus either a flexible coupling with rubber blocks, or rigid coupling is employed to connect the shaft of the generator or the shaft of the speed increaser, if applicable.

MACHINE SELECTION

The following section will furnish information how to determine the type and dimensions of the turbine applicable to a given situation.



KAPLAN TURBINES

GUIDELINES FOR READING THE DIAGRAMS

1. Determine the net head  $H$  (m), the water flow for each unit  $Q$  ( $m^3/sec$ ) and the elevation of the site above mean sea level.

2. Establish the operation field, by matching the values of  $H$  &  $Q$  against each other on fig. 5. The first number defined the runner type, the second the runner diameter.
3. Determine the applicable operation speed using fig. 6

Fig. 1. Tubular arrangement

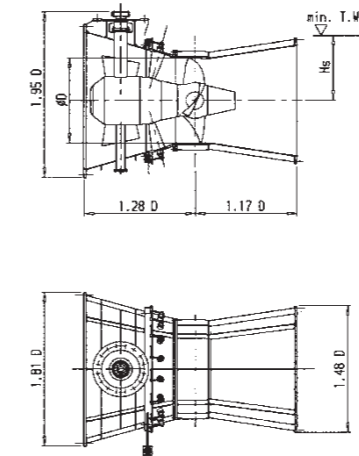

Fig. 3. Pit type arrangement

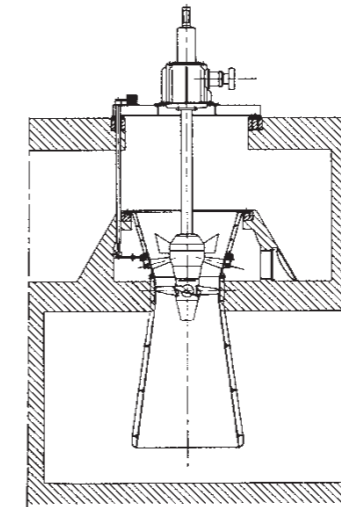

Fig. 2. S-type arrangement

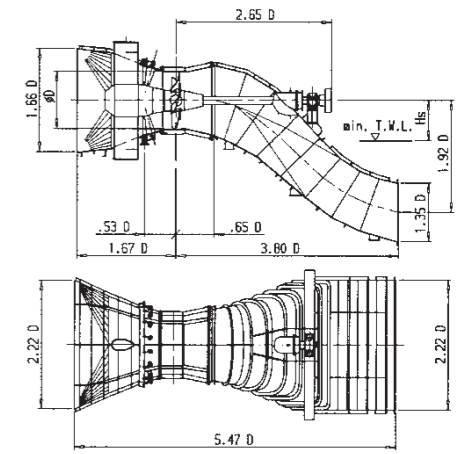
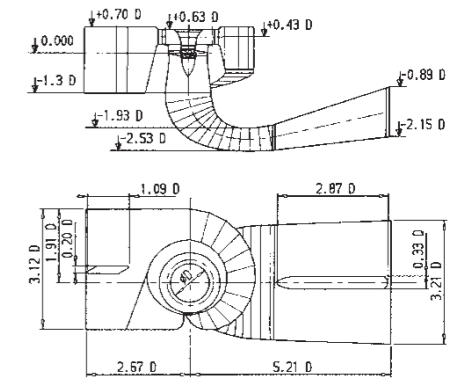

Fig. 4. Concrete soiral case



## KAPLAN TURBINES

- Define the acceptable suction head, using fig. 7. From the obtained suction head subtract 1 m for every 1000 m of elevation.
- Select an arrangement, remembering that the maximum output a bevel gear can take is 1000 kW and that over 2500 mm runner diameter, the S-type Kaplan has excessive excavation costs.
- Determine the main dimensions of the selected machine arrangement in ratio of runner diameter using the corresponding fig. 1-4.

Fig. 5. Machine selection chart for Kaplan turbines

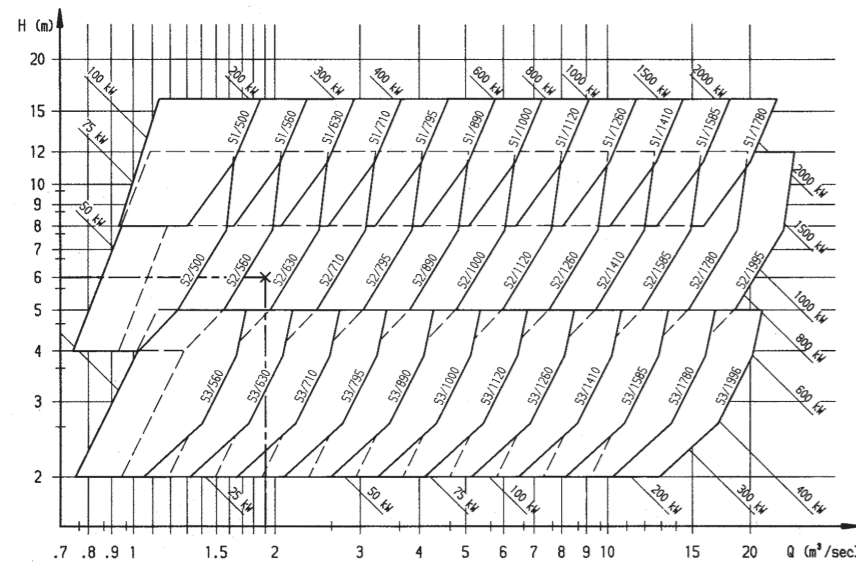

Fig. 6. Applicable speeds

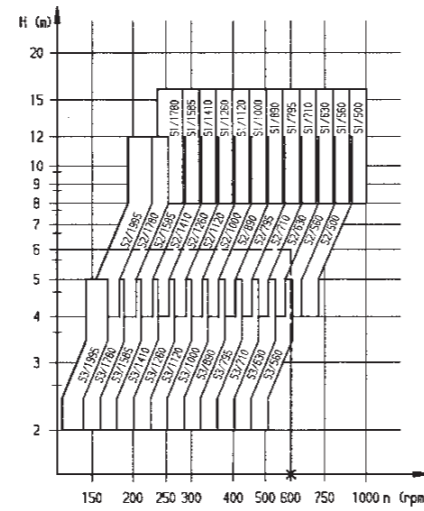
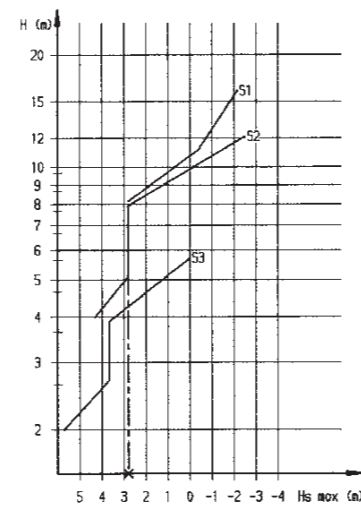

Fig. 7. Admissible turbine settings above tail race level



## PELTON TURBINES OUTPUT RANGE 0,1-5 MW

### ARRANGEMENT

Our standard Pelton turbines have horizontal shaft arrangement, differing in jet numbers only. The runner is directly mounted on to the free flanged shaft of the generator.

Single jet machine is usually used for smaller outputs, having relatively high head and constant flow to reach the highest possible efficiency. The double jet machine may be used to improve the efficiency curve over a wider range of partial loads.

Three alternative branch pipes have also been designed optimizing their space requirements and the losses incurred due to flow resistance. Alternatively machines having their own bearings are also offered for larger outputs, facilitating the installation of a standard generator.



Pelton turbine erection, Canon Del Pato, Peru

### ANCILLARY EQUIPMENT

#### Frequency governor

A plant operating Stand-alone, continually or periodically, must be equipped with a frequency governor. Our digital governor automatically controls the frequency and takes care of all other functions, facilitating unattended operation.



Runners for Mungpoo, Khalikola, India

### CONTROL

The turbine regulation is done by independent jet needles, controlled by directly connected hydraulic cylinders. On account of the long penstock, the flow cannot be blocked suddenly for fear of the effect of water hammer, thus, a jet deflector system is also incorporated to facilitate sudden flow reduction to the runner.

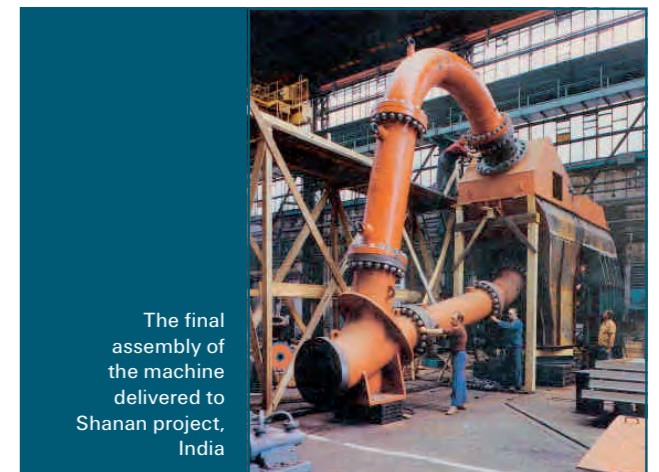

The final assembly of the machine delivered to Shanan project, India



PELTON TURBINES

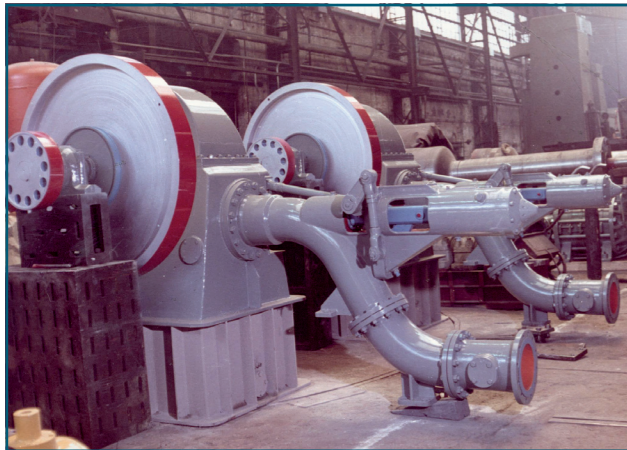

Single jet turbine prior to shipment

*Turbine controller*

For a plant operating continually parallel with a large grid and having an asynchronous generator installed, an output and/or water level regulator is adequate.

*Hydraulic power unit*

The hydraulic power unit is responsible for continually supplying the pressurized oil to the governor/controller unit. It consists of electric motor driven pump(s), a pressure accumulator, various valves and safety devices.

*Main inlet valve*

Normally a spherical valve is installed in front of the manifold. It is actuated by double acting hydraulic cylinder on the commands of the unit controller. Alternatively, for a small output unit with relatively low head, a butterfly valve with closing weight and hydraulic cylinder operation may also sufficient.

EFFICIENCY

Five basic runner types were developed and extensively model tested. The effect of the independent needle control, as illustrated in the former relative efficiency diagram, is a flatter curve over a wide operating range.

TECHNICAL SPECIFICATION

The basic concept was in the design, to find the optimum point of the technical and economical considerations.

*Runner*

The integrally cast stainless steel runner has carefully machined and hand polished surfaces, where the jet comes in direct contact with it. It is statically and dynamically balanced.

PELTON TURBINES

*Jet pipes*

The pipe and the manifold is a welded construction complete with standard flanges. The parts exposed to extensive wear, like the needle and the mouth piece, are made of stainless steel and they are easily replaceable. The axle connecting the needle and its hydraulic cylinder is made of carbon steel, fitted with replaceable protecting sleeve.

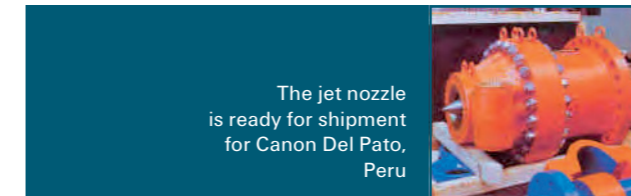

The jet nozzle is ready for shipment for Canon Del Pato, Peru

*Jet deflector*

The jet deflectors are steel castings with replaceable stainless steel tips. The deflectors are supported in dry sliding bearings and operated by a common hydraulic cylinder and suitable rod work.

*Casing*

The casing is fabricated from plain carbon steel plates, having removable runner cover, lugs for lifting and a brake jet facility

*Shaft sealing*

A series of labyrinth rings are mounted on the shaft, while the turbine casing is fitted with an efficient drainage.

*Bearing*

The versions having their own bearings are fitted with a pair of oil lubricated spherical roller bearing.



Pelton runner

PELTON TURBINES

MACHINE SELECTION

This section will furnish information for you to determine the type and physical dimensions of the turbine, applicable to a given project.

Guidelines for reading the diagrams

1. Determine the net head H (m), and the water flow for each unit Q (m<sup>3</sup>/sec).

Fig. 1. Horizontal shaft Pelton turbine dimension

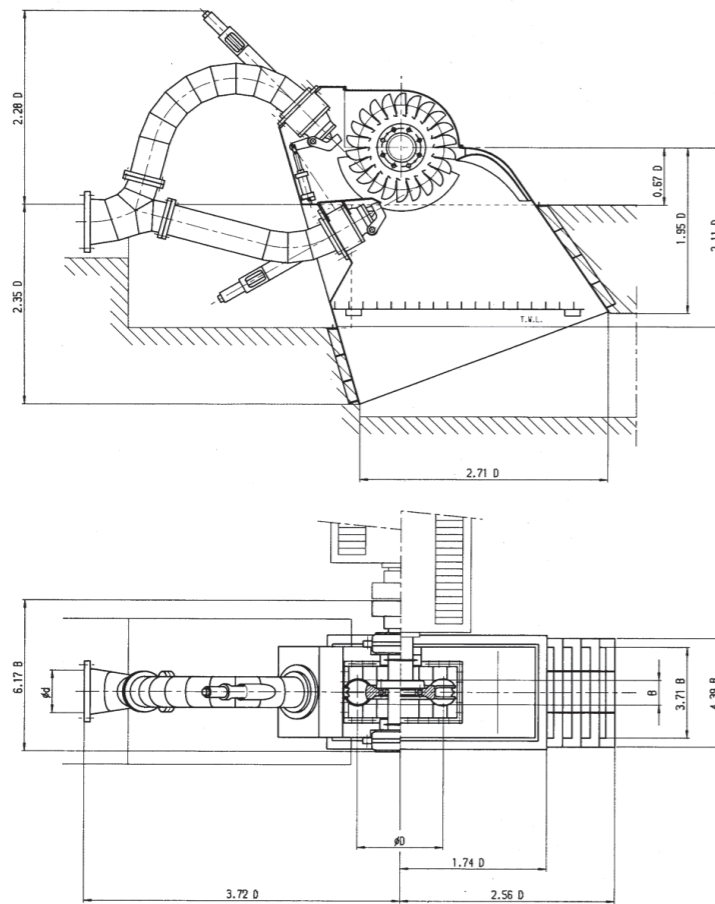

PELTON TURBINES

2. Establish the operation field, by matching the values of H & Q against each other on fig. 2. The first number defines the runner type, the second the runner diameter and the last one denotes the speed.

Fig. 2. Machine selection chart for Pelton turbines

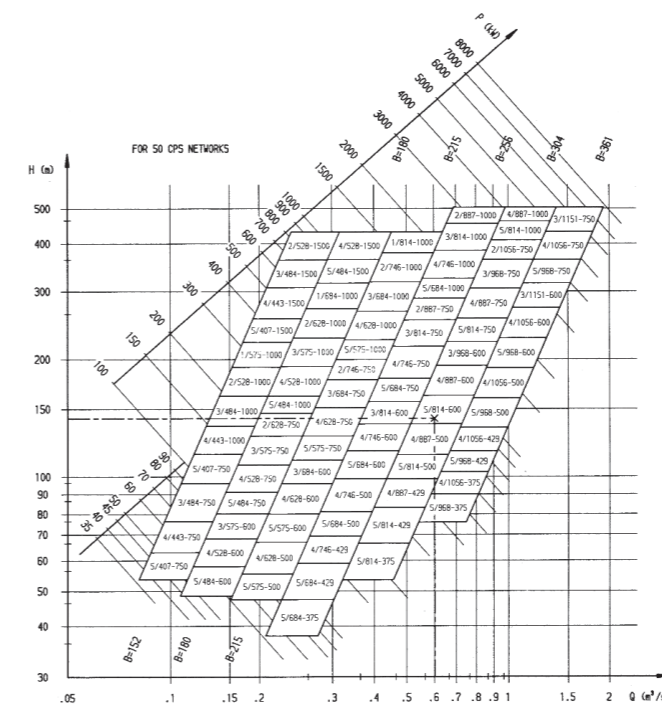

3. Determine the applicable bucket width from fig. 3.
4. Determine the main dimensions of the turbine in ratio of runner diameter using fig. 1.

Fig. 3. Determination of the inlet pipe diameter in function of flow rate

Example for using the charts:

- Head: H = 145 m
- Discharge: Q = 0.6 m<sup>3</sup>/sec
- Turbine output: P = 700 kW
- Bucket width: B = 304 mm
- Inlet pipe dia.: d = 300 mm
- Runner type: 4
- Nominal runner dia.: D = 814 mm
- Speed: n = 600 rpm
- Designation of turbine: P 5/304/814-600

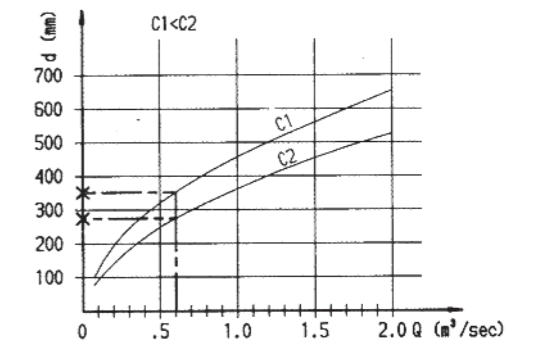

## A FEW INTERESTING HISTORICAL FACTS...



Our first turbine from 1866

The first turbine, a Girard type was delivered as early as 1866 and it served for 84 years with one refurbishment.

Dr. Victor Kaplan, inventor of the turbine named after him today, begun his career and sold the sole right of his license to Ganz in 1913.

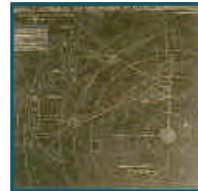

The original drawing of Dr. Victor Kaplan



The 9000 mm Pelton runner at Janerburg, Austria from 1895

One of our early Pelton turbines was fitted with a runner, having a diameter of 9000 mm (Janerburg).

Donát Bánki, also offered his license to Ganz and the first Banki turbine, or Crossflow turbine, as sometimes called, were manufactured in our workshops.



A tandem Banki or Cross-flow turbine prototype in our workshop



Erection of one of the Francis turbines at Almissa, Dalmactia in 1926

In 1926, the Almissa plant in Dalmatia had the largest installed capacity in the world and all the 8 Francis turbines were supplied by Ganz & Comp.

## A FEW INTERESTING HISTORICAL FACTS...

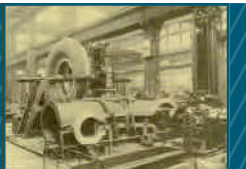
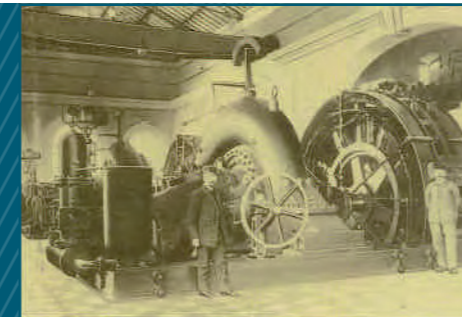
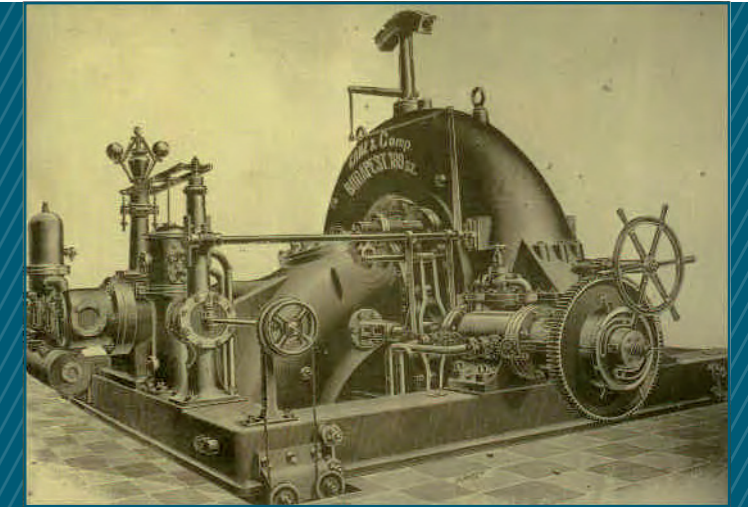



**atomenergomash**

## **Ganz Engineering and Energy Production Machinery LLC.**

Budapest, Kőbányai út 21.  
H-1087 HUNGARY

Phone: (+36)-1-872 5800  
Fax: (+36)-1-872 5801

Web: [www.ganz-eem.com](http://www.ganz-eem.com)  
E-mail: [info@ganz-eem.com](mailto:info@ganz-eem.com)

**INNOVATION DRIVEN BY TRADITION**